

4 x ϕ 13 THRU ALL

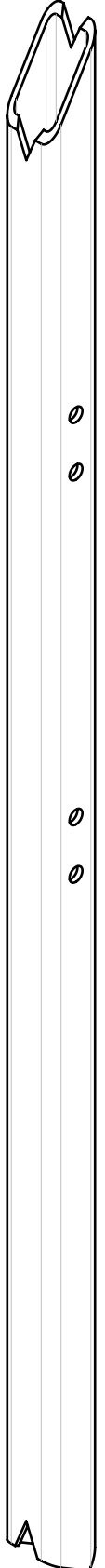
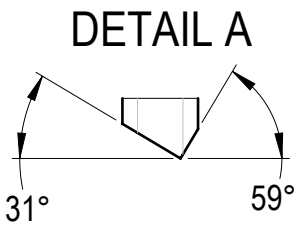
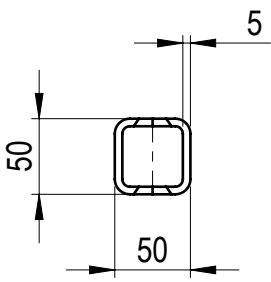
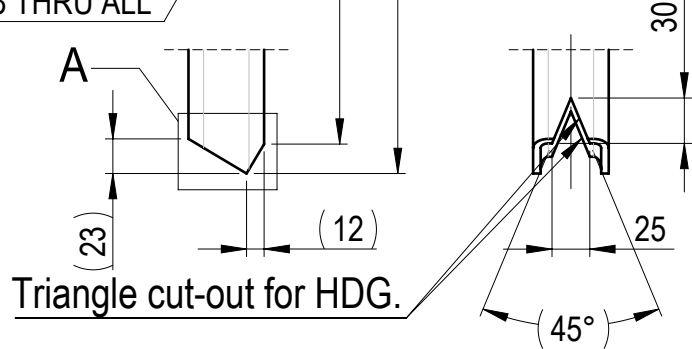
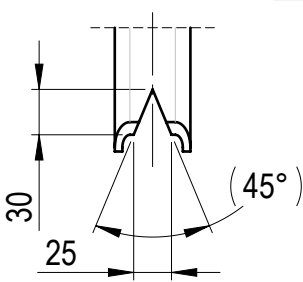

Cut-outs may be made using hand tools

RAW MATERIAL INFORMATION	
Profile size	SHS 50x50x5.0
Length, mm	1339.7

	MATERIAL	WEIGHT	DEBURR AND BREAK SHARP EDGES DO NOT SCALE DRAWING		REVISION	DATE
	S355J2	8.281 Kg				04.06.2025
	SURFACE PROTECTION	MACHINING	THERMAL CUTTING	WELDING	SCALE	FORMAT
	-	ISO 2768 mK	ISO 9013 221	ISO 13920 BF	1:5	A4
	NAME	SIGNATURE	PART NO.			
Designed by	D. Dislers		105-09225-02			
Drawn by	E. Kriviss		DESCRIPTION			
Technical ref.			Outside diagonal tube 5			SHEET 1/1